

# KID LOCKER ASSEMBLY INSTRUCTIONS

## General Instructions

1. Check material received against the packing list. Check the number of packages received and then check the contents of each package.
2. Check the material received for damage. If damage has occurred, secure a “damage notation” from the carrier
3. Identify each part as it is unpacked and put like parts together as close as possible to the working area where they are to be assembled.
4. Be careful to use the correct hardware as specified in the assembly instructions.

## CAUTION

In the interest of safety, all lockers must be securely anchored to the floor and/or wall. For safety, handle all components carefully and wear work gloves when assembling lockers. Install all units plumb and tighten all hardware securely. Retain instructions for future reference.



866-566-0500  
info@Hallowell-List.com  
www.Hallowell-List.com

# KIDS LOCKER ASSEMBLY INSTRUCTIONS - HKL1515(24)-1

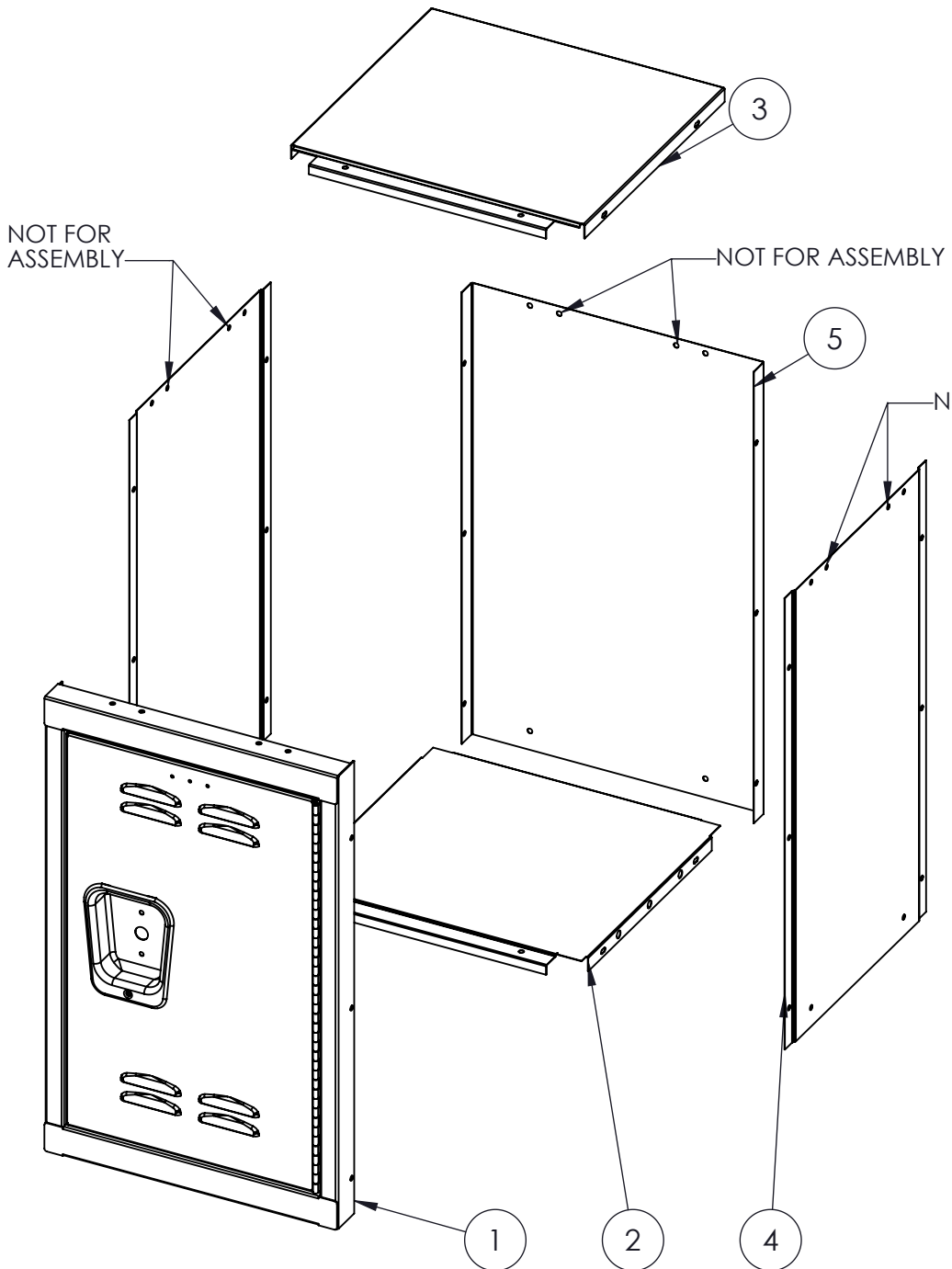

PACKAGE CONTENTS			
ITEM NO.	PART NUMBER	DESCRIPTION	QTY.
1	KDHF1524-1LV	DOOR-FRAME	1
2	KS1515-HKL	BOTTOM- KIDS LOCKER	1
3	HTLC1515	HOME TEAM LOCKER CAP	1
4	KP1524-HKL	SIDE PANEL	2
5	KR1524	BACK	1
6	MBT200	3/8" SLOTLESS BOLT	30
7	N201	HEX NUT	28
8	N110	DOME HEX NUT	2
9	RPE100	ESCUTCHEON PLATE	1

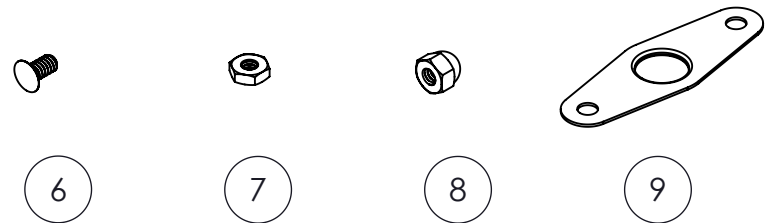

NOTE: FINGER TIGHTEN ALL NUTS, ENSURE UNIT IS SQUARE, THEN TIGHTEN ALL.

1) Bolt Side panels (4) to the inside of the rear panel (5). With bolt (6) and nut (7).

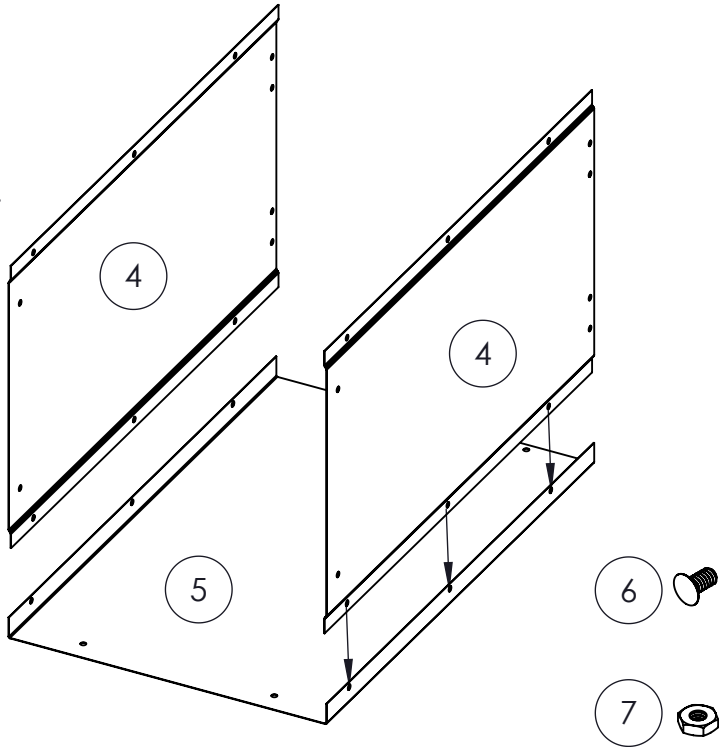

2) Bolt Top (3) to the outside of the side and rear panels. With bolt (6) and nut (7).

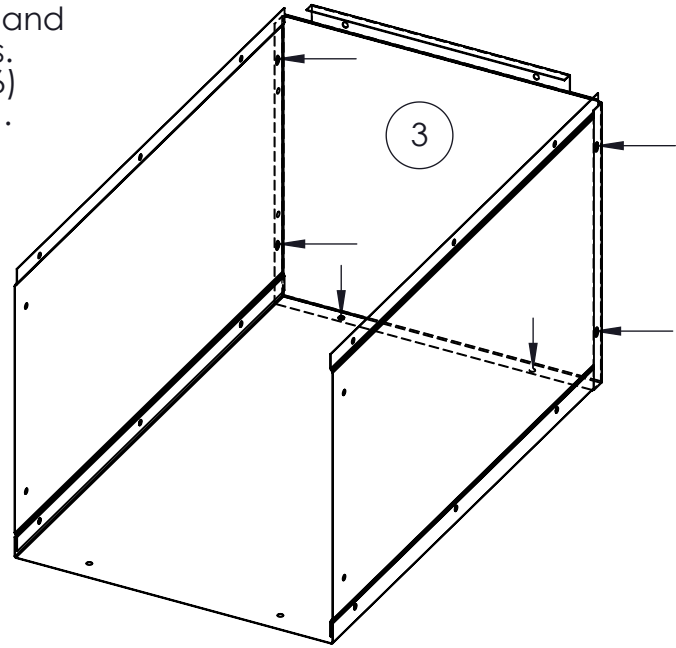

3) Bolt Bottom (2) to the inside of rear and side panels. With bolt (6) and nut (7).

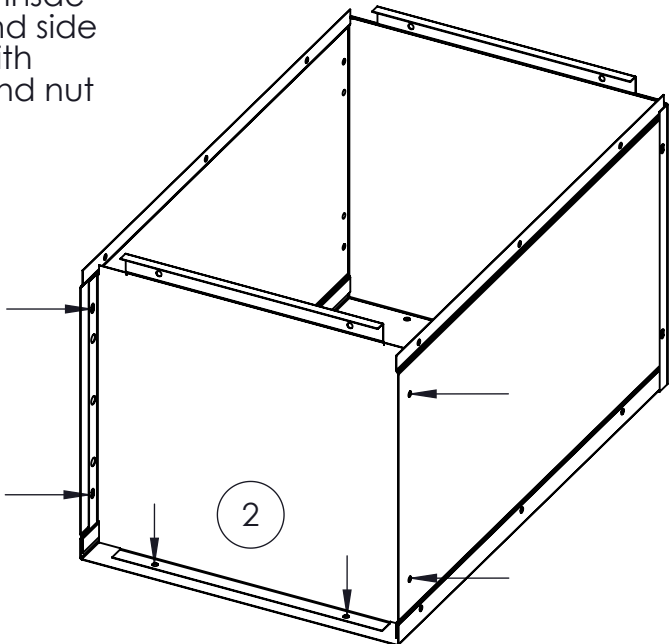

5) Place the Frame (1) on the locker and bolt it on to top, side, bottom and top. With bolt (6) and nut (7). Bolt Escutcheon plate (9) with bolt (6) dome nuts (8). Tighten all hardware

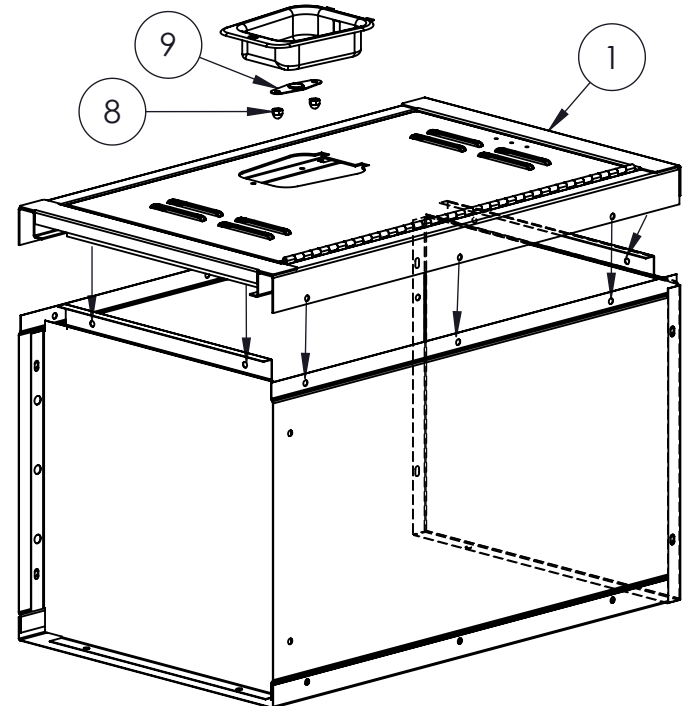

# PERSONALIZE YOUR NEW LOCKER



For just \$10, receive an authentic engraved locker name plate!

## HOW TO ORDER

- Fill out all information below
- E-mail completed form to Sales@Hallowell-List.com or fax to 407-464-3610

Name to be engraved: \_\_\_\_\_ (max. 10 letters)

### Shipping information:

Name: \_\_\_\_\_

Address: \_\_\_\_\_

\_\_\_\_\_

\_\_\_\_\_

Phone: \_\_\_\_\_

### Billing information:

MASTERCARD  VISA

Card Number: \_\_\_\_\_

Exp. Date: \_\_\_\_\_ Security Code: \_\_\_\_\_

Cardholder Name: \_\_\_\_\_

Signature: \_\_\_\_\_

Authorized Amount: \$10.00

(includes shipping and handling)



Toll Free: 866-566-0500  
www.Hallowell-List.com